

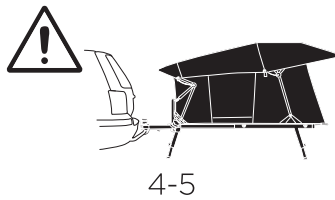

➤ Safety and Maintenance

Thule Rear of Car Tents

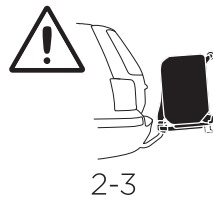

EN	10	ET	34	HR	58
FR	12	LV	36	EL	60
ES	14	LT	38	TR	62
DE	16	RU	40	MT	64
NL	18	UK	42	HE	66
PT	20	PL	44	AR	68
IT	22	CS	46	ZH-SC	69
SV	24	HU	48	ZH-TR	70
DK	26	RO	50	JA	71
NO	28	SK	52	KO	73
FI	30	SL	54	TH	75
IS	32	BG	56	MS	77



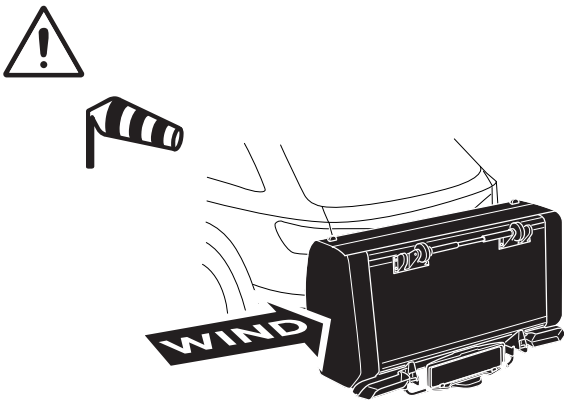
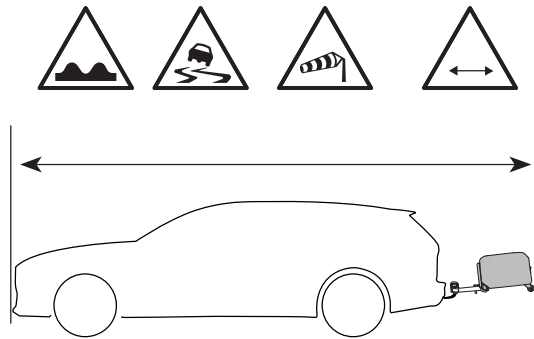
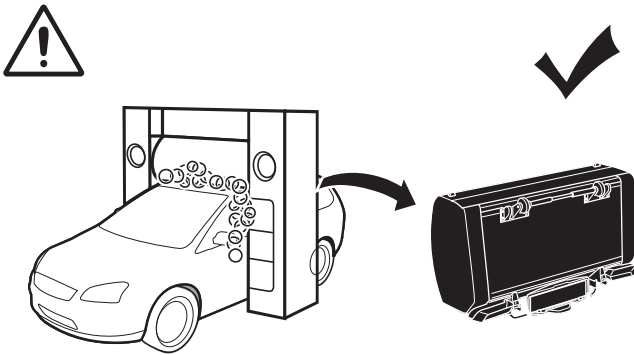
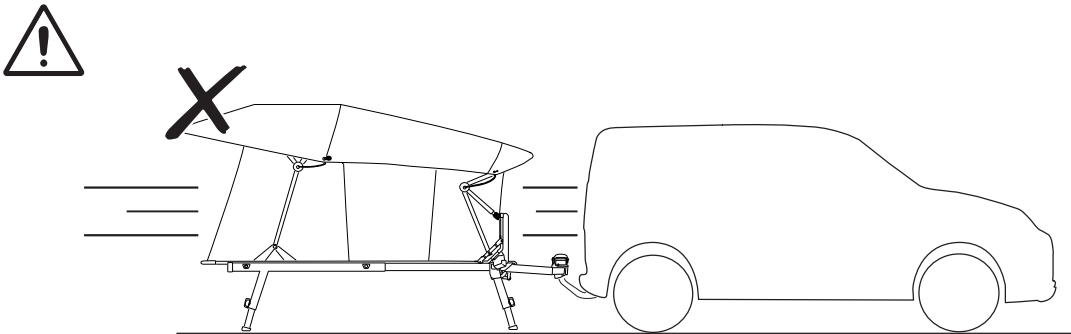
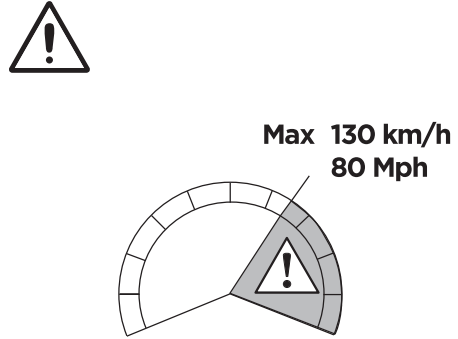
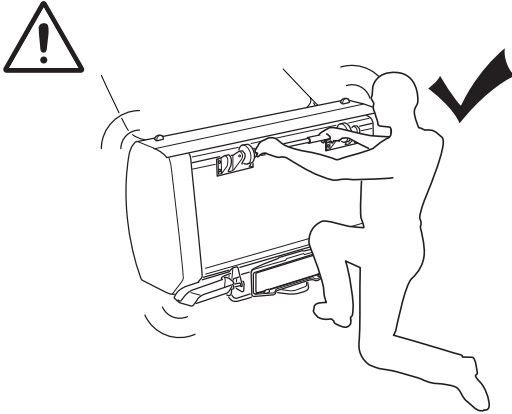

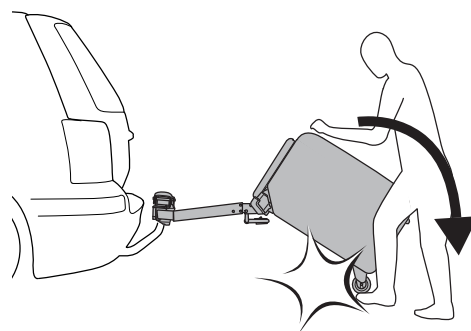
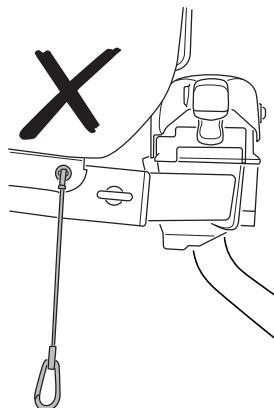
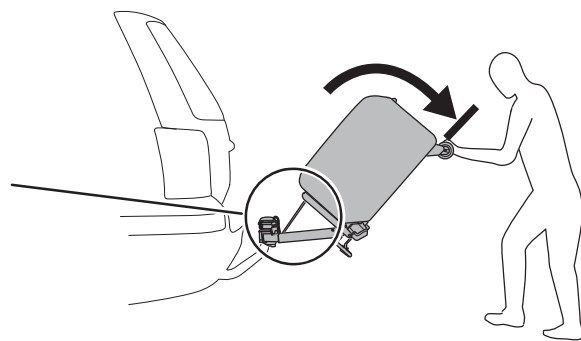
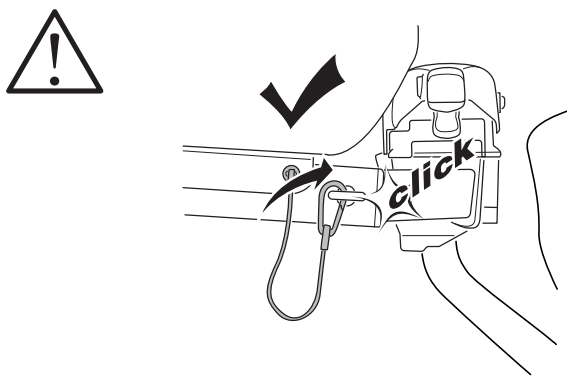
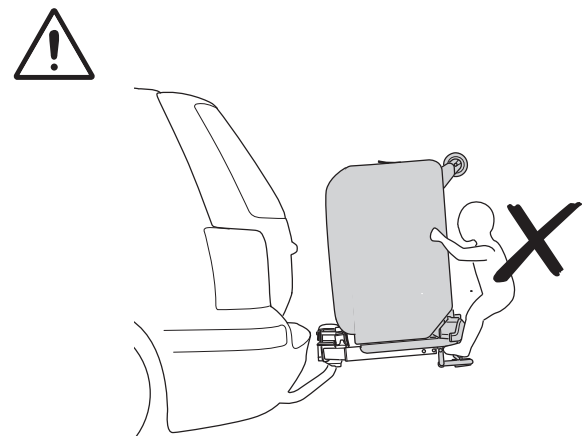
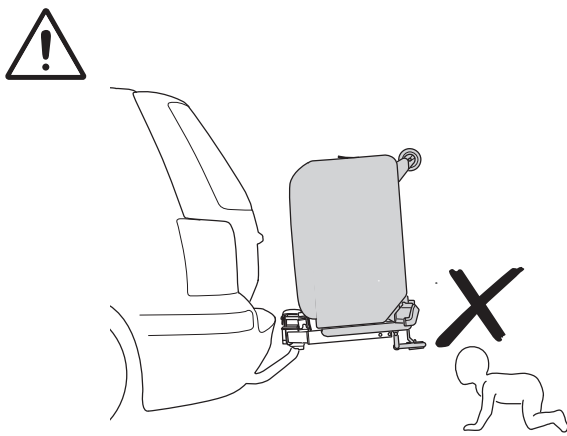
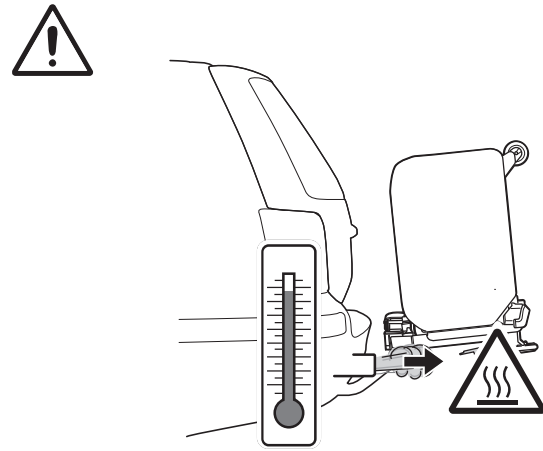
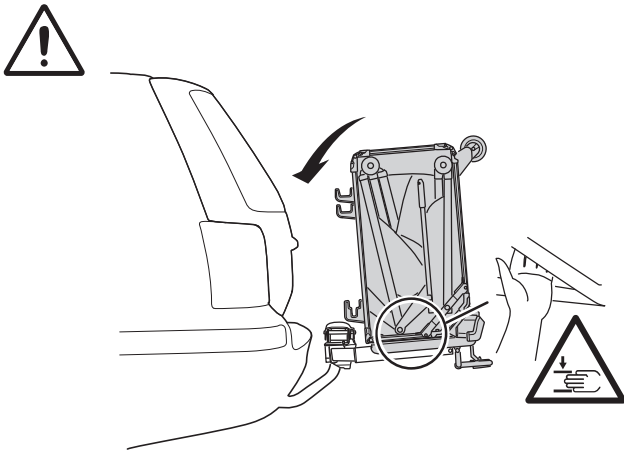

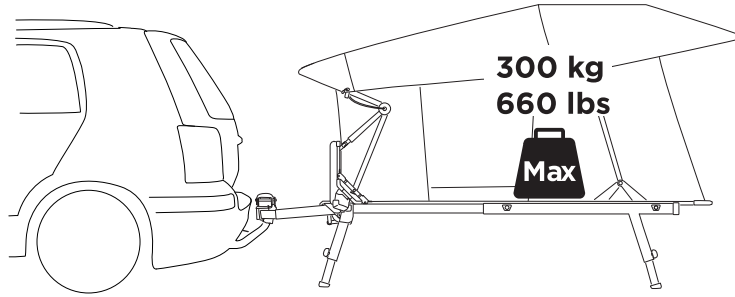
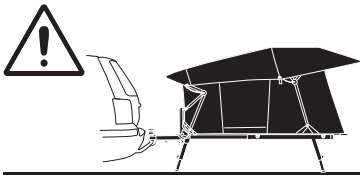

i

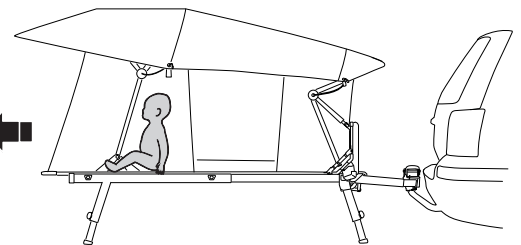
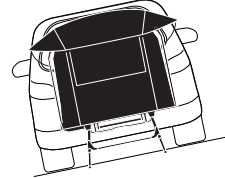
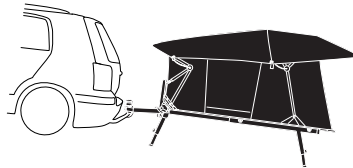
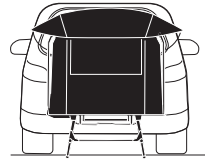
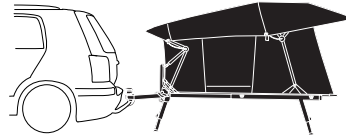
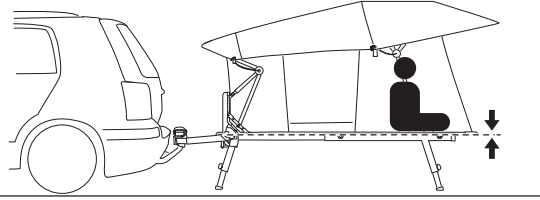
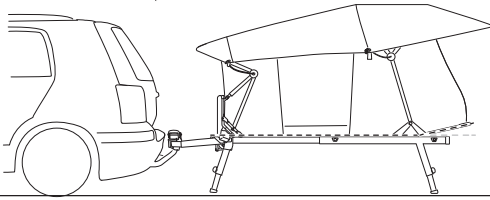

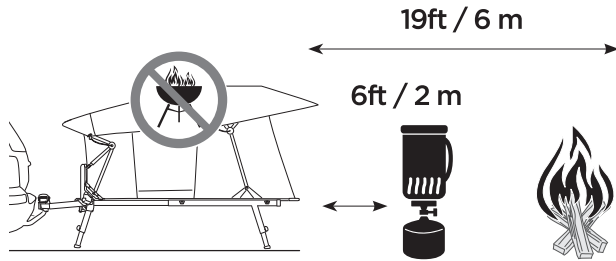
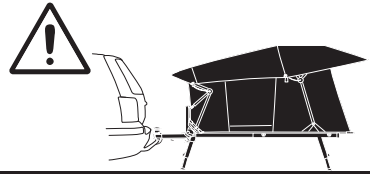

EN Signs of carbon monoxide poisoning.
FR Signes d'une intoxication au monoxyde de carbone.
DE Zeichen einer Kohlenmonoxidvergiftung.
ES Señales de intoxicación por monóxido de carbono.

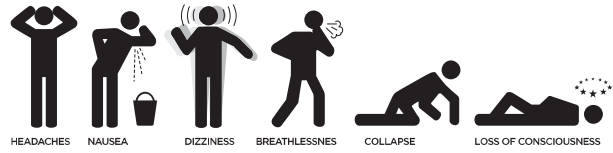

Max 60 °C / 140 °F

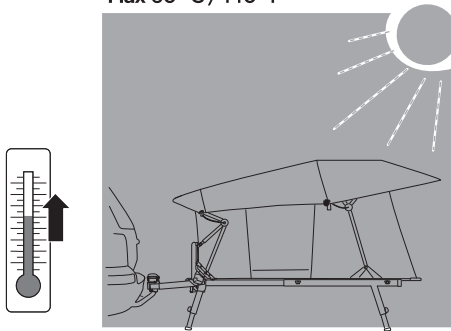

Min -30 °C / -20 °F

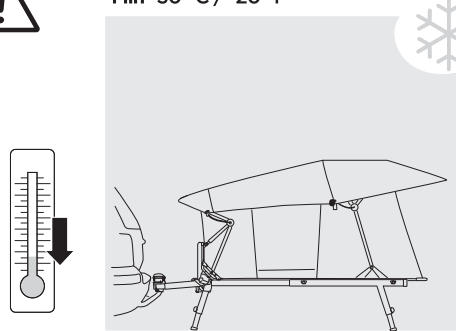



1

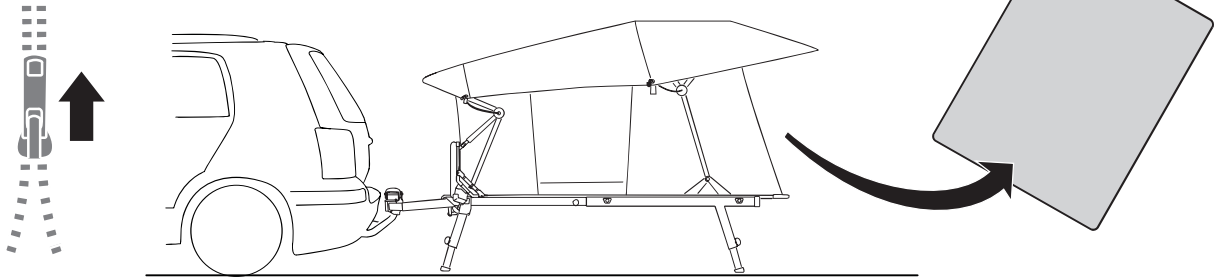

2

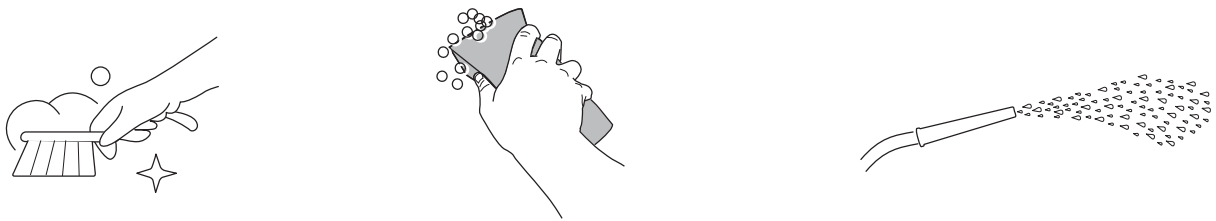

3

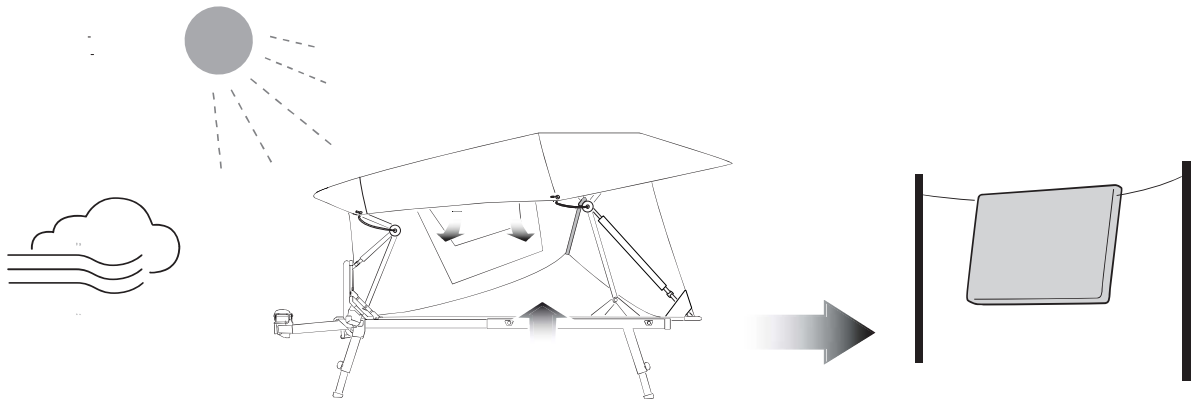

4

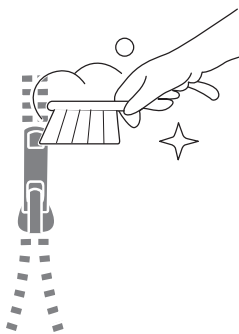

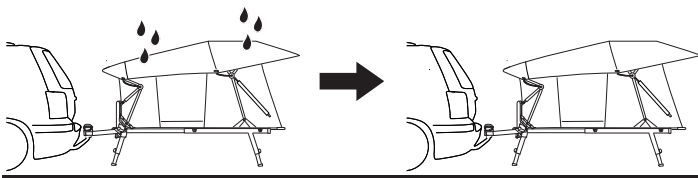

A

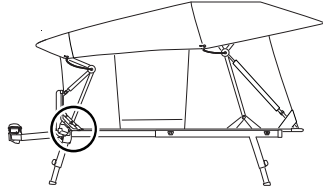

B

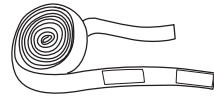

x1

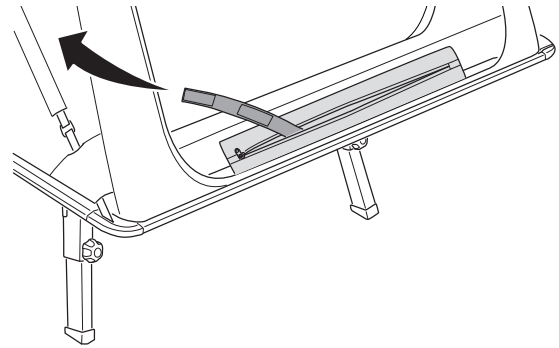
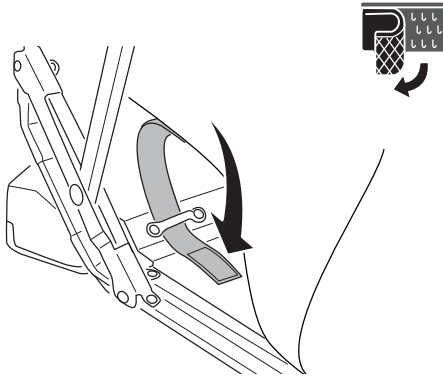

C

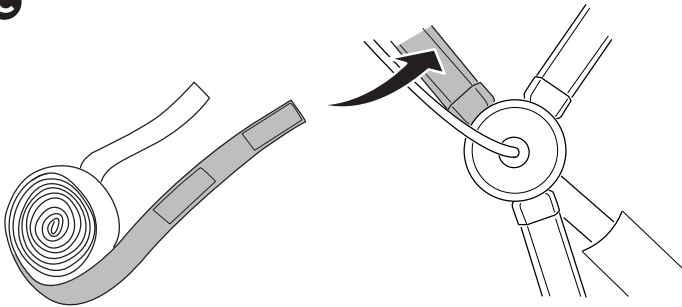

D

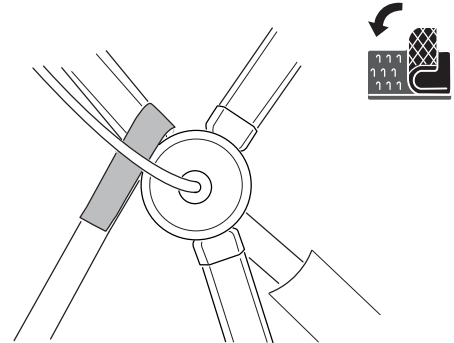

E

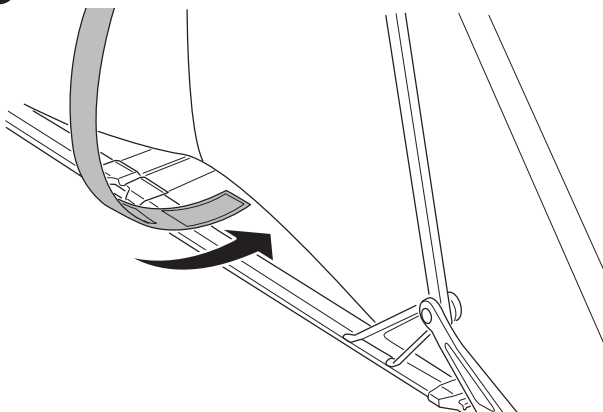

F

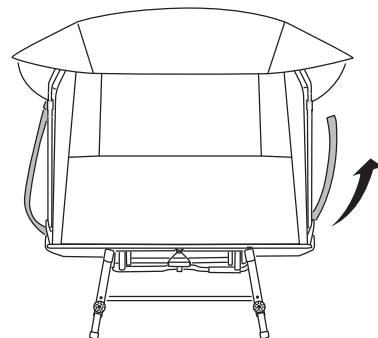

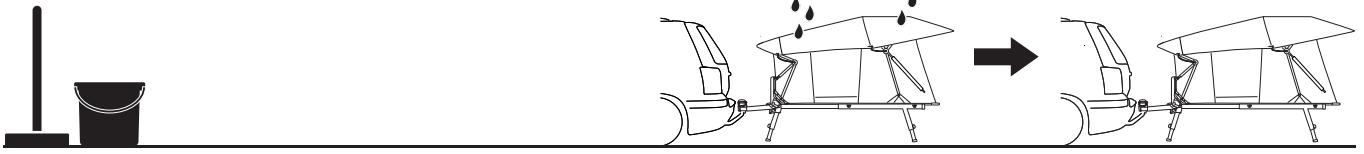

G

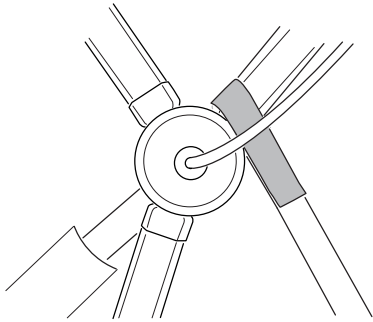

H

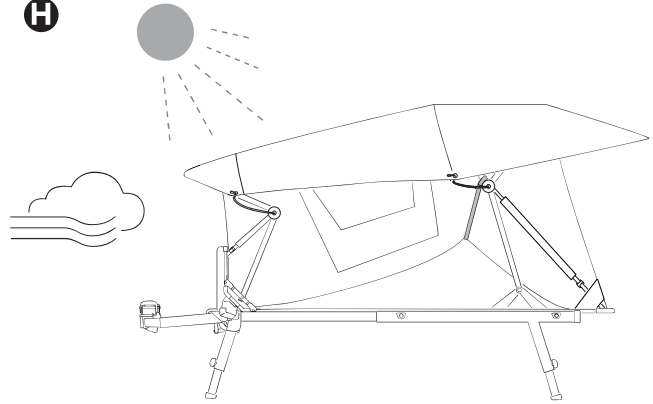

I

x2

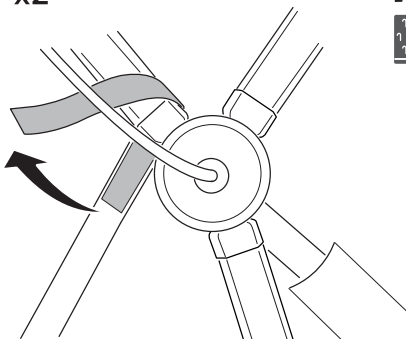

J

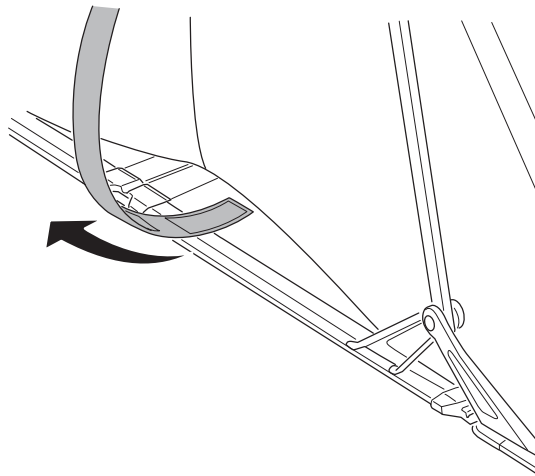

K

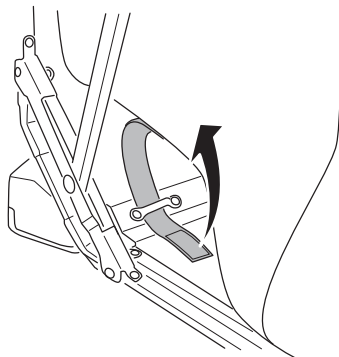

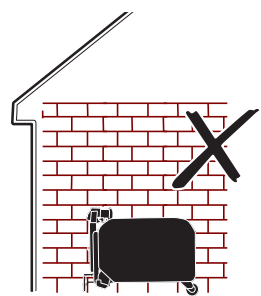
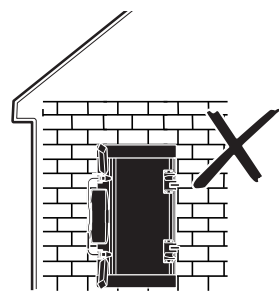
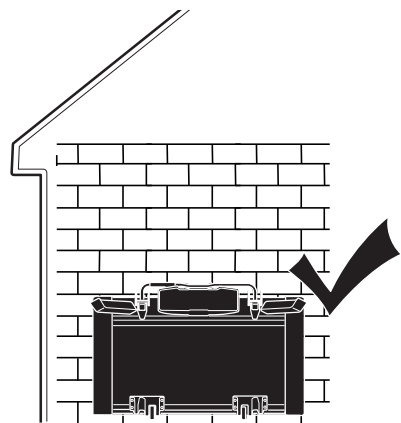
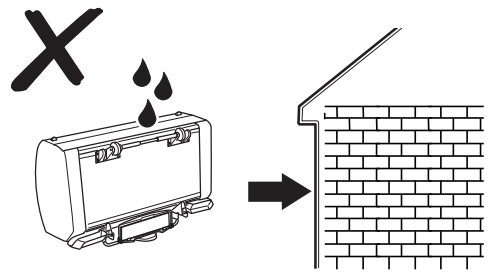
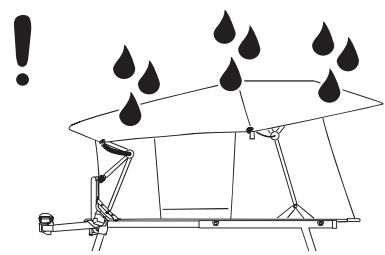
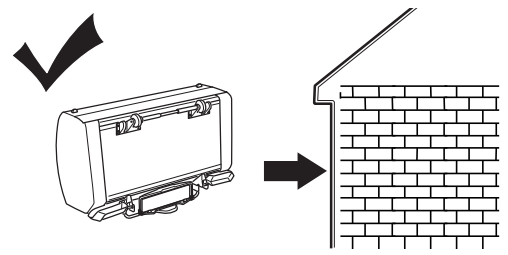
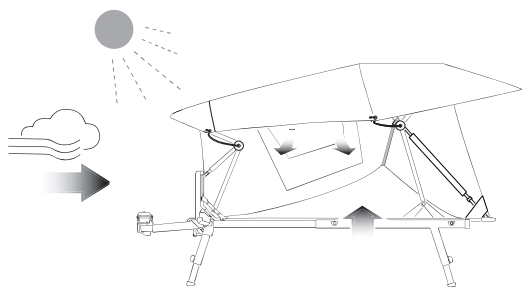

Spare parts / Pièces détachées / Repuestos Ersatzteile / Reserveonderdelen

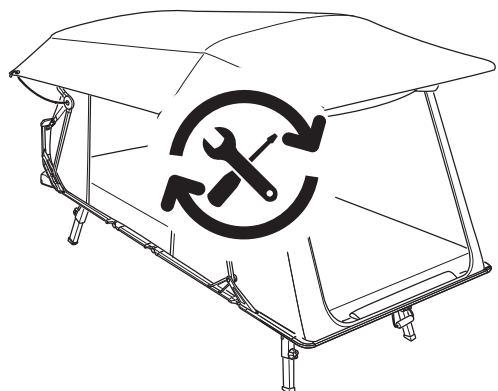

FAILURE TO COMPLY WITH THE MANUFACTURER'S INSTRUCTIONS CAN LEAD TO SERIOUS INJURY OR DEATH. IMPORTANT - READ INSTRUCTIONS AND WARRANTY INFORMATION CAREFULLY AND KEEP FOR FUTURE REFERENCE.

THULE ASSUMES NO LIABILITY FOR INJURY TO PERSONS, DAMAGE TO MOVABLE OR IMMOVABLE PROPERTY, LOSS OF PROFIT, OR ANY OTHER LOSS OR DAMAGE CAUSED BY THE IMPROPER MOUNTING OR USE OF THE CARRIER, INCLUDING BUT NOT LIMITED TO MOUNTING OR USE IN CONFLICT WITH THE ASSEMBLY INSTRUCTIONS, MOUNTING INSTRUCTIONS OR ANY OTHER INSTRUCTIONS GIVEN, IN WRITING OR VERBALLY, BY THULE OR A THULE DEALER.

CONSULT YOUR THULE DEALER IF YOU HAVE ANY QUESTIONS ABOUT THE OPERATION, USE AND LIMITS OF THE PRODUCT.

ASSEMBLY AND MOUNTING

- Check the assembly instructions to make sure that all the necessary parts of the product are present.
- In addition to the product instructions, due consideration should also be given to the operating instructions of the given vehicle.
- The vehicle driver is solely responsible for ensuring that the carrier is in perfect condition and that the carrier is securely mounted (even if mounted by a third person).
- Never mount the carrier on a vehicle with a maximum weight limit lower than the weight of the product. Check the vehicle instruction manual.
- If the vehicle is equipped with an automatic boot or tailgate opening function, this function must be disabled and the luggage compartment must be opened manually when the carrier is fitted, to avoid damage to the vehicle and/or the carrier.
- Do not attempt to fit the carrier in any other way than the way shown in the mounting instructions.
- Do not modify the product in any way.
- The tow bar-mounted carrier is not suitable for tow bars made entirely of aluminium or GGG40 (cast iron).
- The tow ball and the cylindrical part of the tow bar which reaches 2 cm below the tow ball must be made of steel. However, the tow ball holder can be made of aluminium.
- The weight of the carrier and the load must never exceed the permitted tow bar capacity. Information about the tow bar capacity can be found on a plate next to the tow bar or in the vehicle information booklet.
- Always check that the tow ball is free of dirt and oil and not damaged. Some tow ball manufacturers cover their tow balls with protective foil or coating. This foil or coating must be removed before using the carrier, as it has a negative effect on friction and stability.
- If the carrier moves on the tow ball or if the clamping force is reduced when operating the fastening handle, the tow ball's clamping force must be adjusted in accordance with the mounting instructions. Ask your local Thule dealer for advice or assistance.
- Keep a safe distance between the carrier and the exhaust pipe to avoid heat damage to the carrier. The hot exhaust pipe and/or the hot exhaust gas could damage components of the carrier. On certain vehicle models an exhaust pipe extension is required. Consult your Thule dealer if you are in doubt about the requirements that apply to your vehicle.
- An additional number plate might be required. This should be attached to the appropriate part of the carrier in accordance with local laws.

- Keep the mounting and safety instructions and (if applicable) the ECE Type Approval in the vehicle where the carrier is mounted.

USE

- Never attach additional items to the carrier when it is folded on the vehicle.
- Every time the carrier is used, check that the carrier is securely fitted after driving a short distance (50km) and then at regular intervals. If you notice any unusual noise, movement of the carrier, different behaviour of the vehicle or other unusual conditions, stop and check that the carrier is secured correctly, and in accordance with the mounting instructions.
- Before driving away, ensure that the cover is properly attached to the folded tent. Check at regular intervals on longer trips and every 2 hours when driving on rough terrain.
- Do not drive a vehicle while the tent is deployed.
- The vehicle's speed must always be adjusted to the load being carried and the current driving conditions, such as the road type, road quality, wind conditions, traffic intensity and applicable speed limits, but must under no circumstances exceed 130 km/h (80 mph). Applicable speed limits and other traffic regulations must always be observed.
- Drive slowly over speed bumps, maximum speed 10 km/h (6.2 mph).
- Remove the carrier before using an automatic car wash.
- It is recommended to remove the carrier when it is not in use.
- If necessary, the load must be fitted with the appropriate lights and warning signs in accordance with local laws.
- In the case of vehicles first type-approved after 1 October 1998, the rear-mounted carrier and/or the load must not cover the vehicle's third brake light. The vehicle's third brake light must be visible from:
 - 10 degrees to the left and to the right of the longitudinal axis of the vehicle.
 - 10 degrees above and 5 degrees below the horizontal axis. If these figures are not complied with, an optional replacement brake light must be fitted. National laws must be taken into account while using the carrier.
- Before departure, the functioning of the lights must be checked. When using the fog light on the carrier, make sure that the fog light on the vehicle is not switched on at the same time. The vehicle's fog light normally switches off automatically when the vehicle detects that the plug is connected. Check if this is the case.
- If the carrier has a tilting mechanism for easy access to the boot, make sure that the mechanism is securely locked in the transport position during transportation.
- The vehicle's total length and/or height may increase when a carrier is mounted. Take special care when reversing and/or entering garages or ferries etc.
- Do not let the load exceed national regulations in regards to vehicle width. For safety reasons, Thule Group recommends to not carry loads wider than the vehicle width.
- Replace any damaged or worn parts of the carrier immediately. During transportation, all levers, bolts and/or nuts must be tightened in accordance with the mounting instructions.
- Be aware that the vehicle's driving characteristics and braking behaviour (including in curves) might change and that the vehicle might become vulnerable to side winds when the carrier is fitted.

DEPLOYED TENT

- KEEP ALL FLAME AND HEAT SOURCES AWAY FROM THE TENT FABRIC. The tent meets the flammability requirements of CPAI-84 and CGSB 182-1. The fabric may burn if left in continuous contact with any flame source. The application of any foreign substance to the tent fabric may render the flame resistant properties ineffective.
- Do not use fuel-burning or oxygen-consuming devices inside or close to the tent. This includes candles, gas lanterns, kerosene lamps and cooking and heating appliances.
- Do not put the tent near a campfire or any other flame source. Keep a distance of at least 19ft / 6 m.
- Fall or strangulation hazard - Never leave a child unattended in the tent.
- Do not allow children to play around or on top of a folded up tent.

Maintenance

- Clean the carrier regularly using warm water or car shampoo, especially when using or after using the carrier in coastal areas (the effect of salt water) or during periods when salt is applied to the roads (winter time).
- Lubricate the coupling mechanism (but not the surfaces in contact with the tow ball surface) and other moving parts of the carrier when required.
- The tent should be carefully cleaned and maintained. For this purpose, only use a solution of water and standard household washing liquid without any alcohol, bleach or ammonium additives as otherwise the surface of the tent could be damaged.
- Thule tents are highly water resistant. Moisture found inside of the tent is likely caused by condensation. To minimize the amount of condensation, always keep windows or vents open. Also avoid keeping wet clothes inside of the tent.
- Thule tent fabrics have a water resistant coating and sealed seams to prevent water from entering the tent during normal use. It is recommended to periodically coat the tent with an additional layer of waterproof spray or add seam sealer to maintain water resistance. These items are commonly found at local outdoor stores.
- Always dry the tent thoroughly before closing it. Failure to do so may cause growth of mold and mildew.
- Prior to closing the tent, lift the mattress and the bottom of the tent fabric and ensure that everything is dry.
- Pull zippers in a gentle fashion, never force, as this may damage the zippers. If a zipper is having trouble, check to ensure that no fabric is caught in the zipper and have someone help reduce tension by pulling the zipper together.
- Ensure that the tent is fully dry and clean prior to storage. Clean and maintain the tent in accordance with the instructions. Store the tent in a dry and cool environment that is free from direct sunlight. The tent should not be stored outside exposed to the elements (e.g. rain or direct sunlight).
- The manufacturer is not liable for any damage or accident that may occur as a result of non-compliance with the usage instructions, modifications made to parts or usage of any parts other than the manufacturer's original parts.
- To ensure that you receive the spare parts quickly and to avoid time-consuming queries, please provide the relevant product details and the serial number when placing an order or making an inquiry.
- In order to ensure that you are able to replace lost or defective keys as quickly as possible, note down the lock and key number which can be found on your key.