



Dear Customer,

Thank you for choosing an UEBLER bicycle rack.

Please observe the work and safety instructions described in these mounting and operating instructions at all times. We will not accept any liability for damage resulting from failure to do so.

Note

This section describes and illustrates how to mount and operate the Uebler i21 S bicycle rack. The procedures for the Uebler i31 S and i41 S bicycle racks are similar.

Parts overview

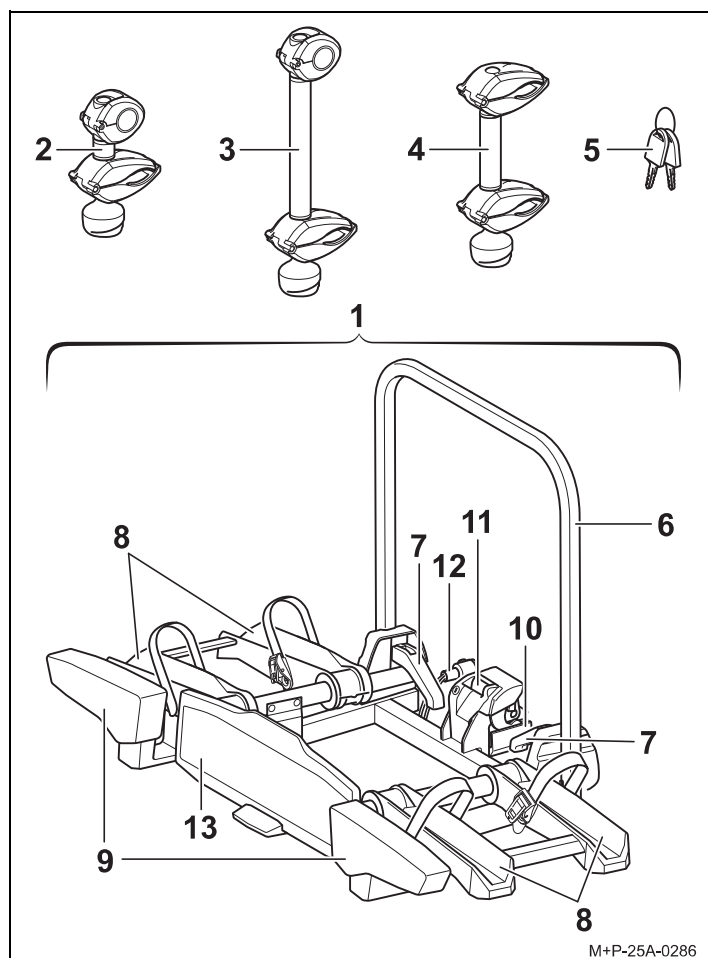

M+P-25A-0286

Order numbers

Uebler i21 S rack for 2 bicycles
Order no. 18100 (left-hand drive)

Uebler i31 S rack for 3 bicycles
Order no. 18120 (left-hand drive)

Uebler i41 S rack for 4 bicycles
Order no. 18140 (left-hand drive)

ECE type approval number

E24 E24*26R04/00*0136*00

Scope of delivery

Designation	i21 S	i31 S	i41 S
	Quantity	Quantity	Quantity
1 Bicycle rack	1	1	1
2 Bracket 1st bicycle	1	1	1
3 Bracket 2nd bicycle	1	1	1
4 Bracket 3rd bicycle	–	1	2
5 Key	6	8	10

Note

The scope of delivery is subject to change. Repairs or replacement of parts must be performed by a specialist workshop. For safety reasons, Uebler recommends only using genuine spare parts available from your specialist dealer.

Note

The holders (2), (3) and (4) are included separately in the delivery package and are not pre-assembled. The keys (5) are inserted in the lock of the holders (2), (3) and (4) and in the lock of the safety lever (11).

Part designation

Designation	i21 S	i31 S	i41 S
	Quantity	Quantity	Quantity
6 Rack frame	1	1	1
7 Quick-release clamp for rack frame	2	2	2
8 Wheel rails	4	6	8
9 Tail light unit	2	2	2
10 Towbar attachment	1	1	1
11 Safety lever for towbar attachment	1	1	1
12 Plug for lights	1	1	1
13 Number plate holder	1	1	1

Technical data

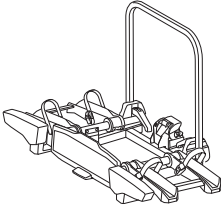
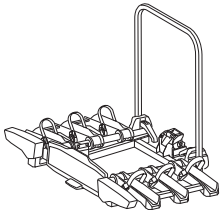
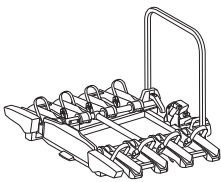
Maximum load (bearing capacity)		
Uebler i21 S: Towbar load ^a – rack weight = max. payload		
Towbar load	Rack weight	Max. payload
110 lbs (50 kg)	 <p>Uebler i21 S = approx. 30 lbs (13.5 kg)</p>	80.5 lbs (36.5 kg)
132 lbs (60 kg)		102.5 lbs (46.5 kg)
154 lbs (70 kg)		124.5 lbs (56.5 kg)
≥ 162 lbs (73.5 kg)		132 lbs (60 kg)
Uebler i31 S: Towbar load ^a – rack weight = max. payload		
Towbar load	Rack weight	Max. payload
110 lbs (50 kg)	 <p>Uebler i31 S = approx. 35 lbs (16 kg)</p>	75 lbs (34 kg)
132 lbs (60 kg)		97 lbs (44 kg)
≥ 154 lbs (70 kg)		119 lbs (54 kg)
Uebler i41 S: Towbar load ^a – rack weight = max. payload		
Towbar load	Rack weight	Max. payload
165 lbs (75 kg)	 <p>Uebler i41 S = approx. 44 lbs (20 kg)</p>	121 lbs (55 kg)
≥ 176 lbs (80 kg)		132 lbs (60 kg)

a If the values for the towbar and the vehicle are different, the lower value must be used.

Electrical connection	
Power supply	13-pin, 12 V

Bicycle weight	
Maximum weight per bicycle ^b	66 lbs (30 kg)

b In the event that the bicycles have different weights, the heavier bicycle must be fitted closer to the vehicle

Maximum tube diameter of bicycle frames	
Round tube	3 inch (75 mm)
Oval tube	3x1.7 inch (75x45 mm)

Attaching and removing the bicycle rack

⚠ Attention

The towbar and the vehicle must be suitable for attachment of a bicycle rack:

- Towbar load (see type plate on the towbar and vehicle operating manual)
- The towbar must be made of St 52-3 or stronger (see type plate on the towbar).

If not, the bicycle rack and the bicycles mounted on it may come loose from the vehicle, injuring you and other persons, or may cause an accident.

The ball head must be cleaned and degreased prior to mounting.

⚠ Attention

Failure to take account of the altered vehicle dimensions (width, height, depth) with the bicycle rack attached may cause injury to you and other persons and/or cause damage to property.

Please take account of the altered vehicle dimensions when driving through entrances and narrow passages. Be careful when reversing.

⚠ Attention

Check that the lights are in perfect working order before each journey, otherwise accidents may occur.

Note

Remove the bicycle rack from the vehicle when not in use.

Mounting the bicycle rack on the vehicle

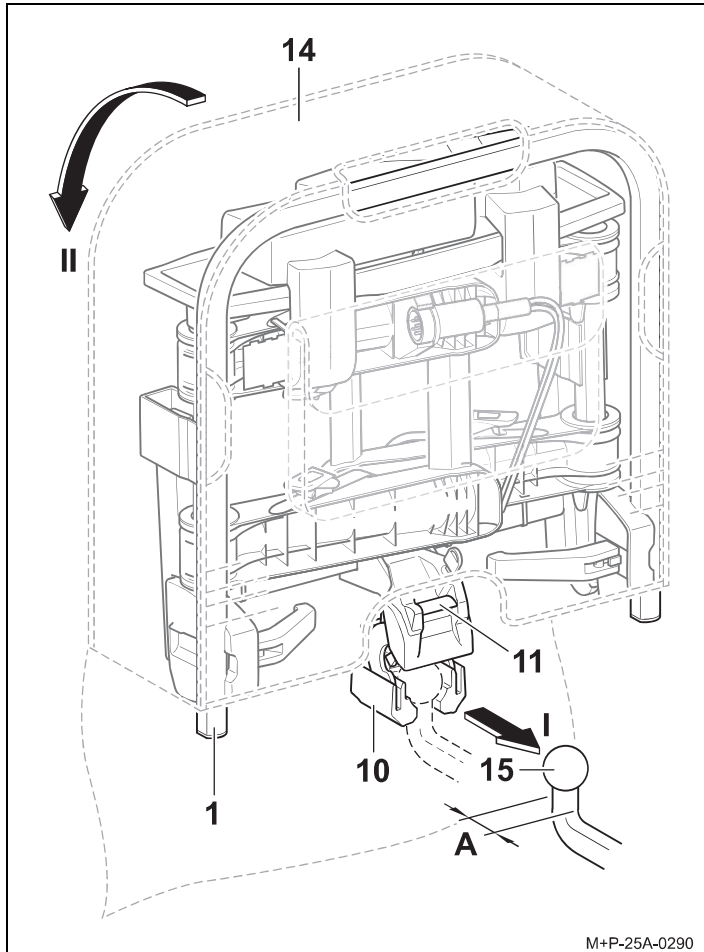

1. Open the flap of the bag¹ (14).
2. Press the safety lever (11) so that the attachment (10) comes out.

Note

For the i41 S bicycle rack, the coupling neck of the towbar (15) must have a diameter of at least 1.2 inch (28.5 mm) (A).

3. Hold the bicycle rack (1) upright and push it with the attachment (10) onto the ball head of the towbar (15) (arrow I).
4. Tilt the bicycle rack (1) downwards until the safety lever (11) audibly engages (arrow II).
The red marking on the safety lever (11) must no longer be visible.
5. Check that the bicycle rack (1) is parallel to the bumper and roughly parallel to the ground.
Shake the bicycle rack (1) to check that it is firmly fitted. If necessary, remove the bicycle rack (1) and fit it again.

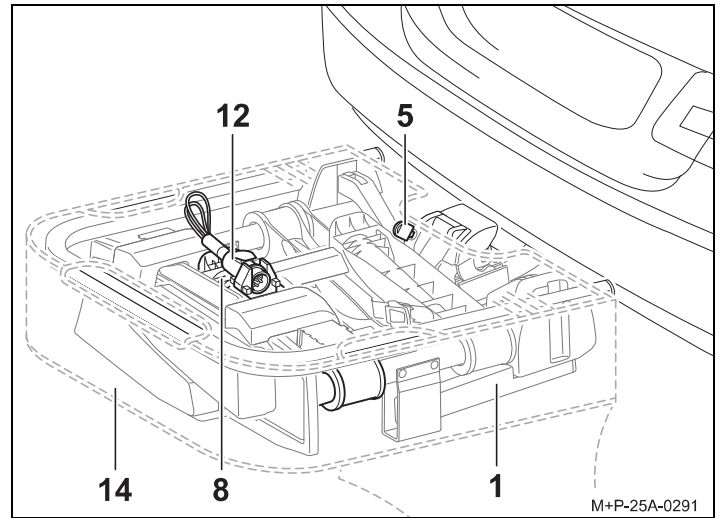

6. Pull the bag (14) off the bicycle rack (1).
7. Lock the bicycle rack (1) using the key (5) and then remove it.
8. Pull the plug (12) out of the plug holder on the wheel rail (8).

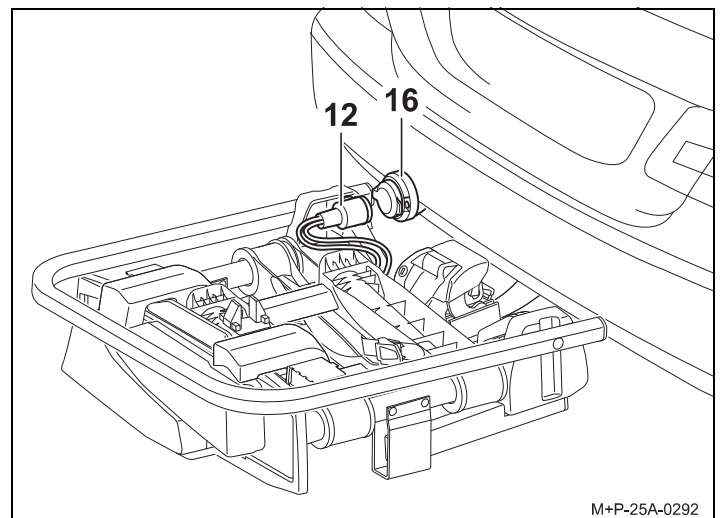

9. Connect the plug (12) to the socket (16) on the vehicle and turn it clockwise as far as it will go.

¹ Bag available as an option (for Uebler i21 S bicycle rack, order no. 25020, for Uebler i31 S bicycle rack, order no. 25030, for Uebler i41 S bicycle rack, order no. 25040).

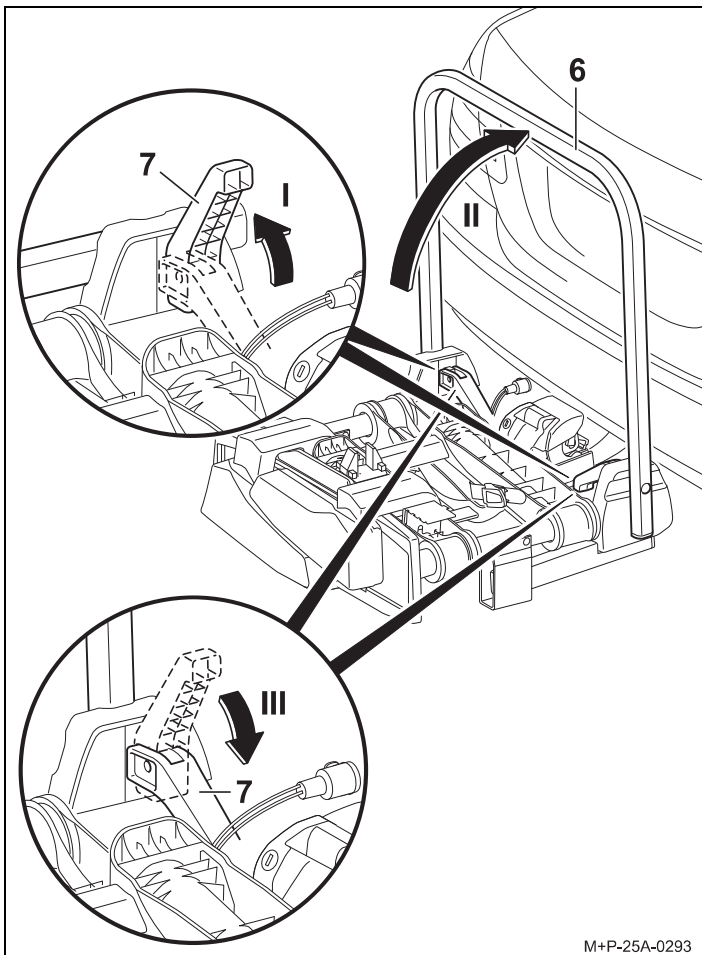

10. Open the quick-release clamp (7) upwards (arrow I) and fold up the rack frame (6) (arrow II).
11. Close the quick-release clamp (7) again completely (arrow III) to fix the rack frame (6) in place.

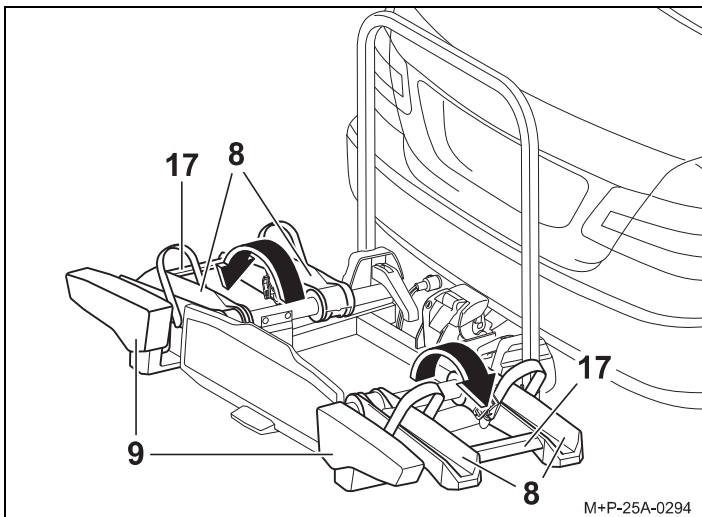

⚠ Attention

Always hold and fold out the wheel rails (8) by holding the crosspieces (17) and not the tail light unit (9). Otherwise the tail light unit (9) may be damaged.

12. Hold the wheel rails (8) at the crosspieces (17), fold them out and lock them in place.
13. Check that the lights work correctly.

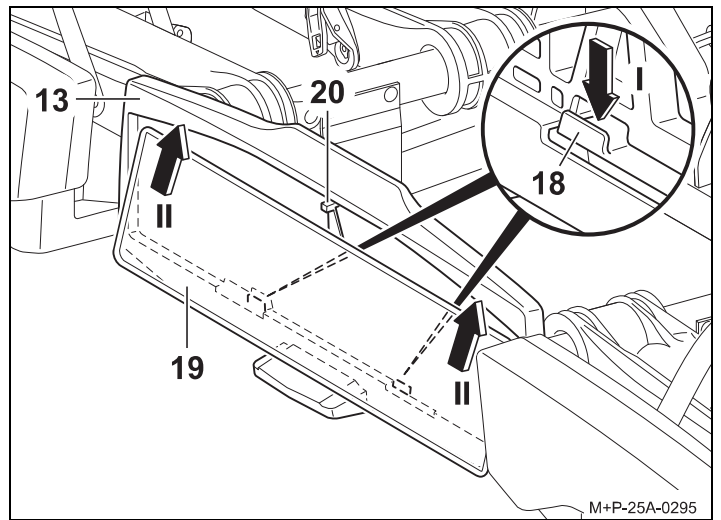

14. Push the holder (18) down (arrow I).
15. Slide the number plate (19) into the number plate holder (13), push it up and press it all the way in (arrow II).
16. Release the holder (18) and check the number plate for tight fit.

Note

To insert larger number plates, press back the stopper (20) and push the number plate all the way into the number plate holder (13).

Note

The number plate on the bicycle rack must match the vehicle's registration number and must be clearly legible.

Removing the bicycle rack

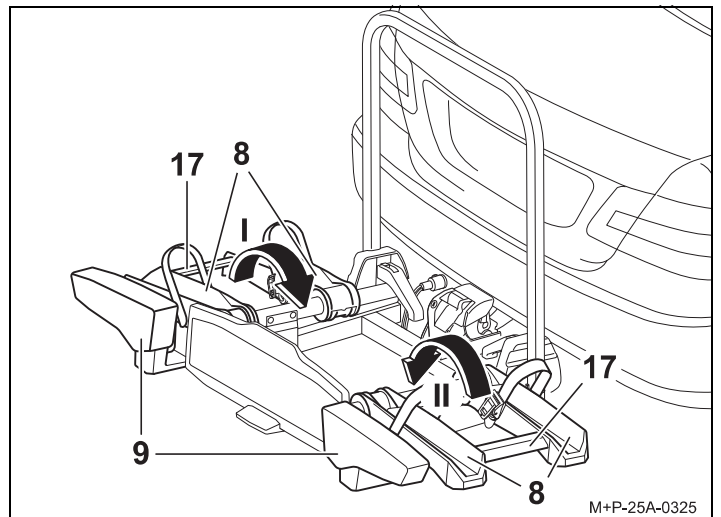

⚠ Attention

Always hold and fold in the wheel rails (8) by holding the crosspieces (17) and not the tail light unit (9). Otherwise the tail light unit (9) may be damaged.

1. Hold the left side of the wheel rail at the crosspiece (17) and fold it in (arrow I).
2. Hold the right side of the wheel rail at the crosspiece (17) and fold it in (arrow II).

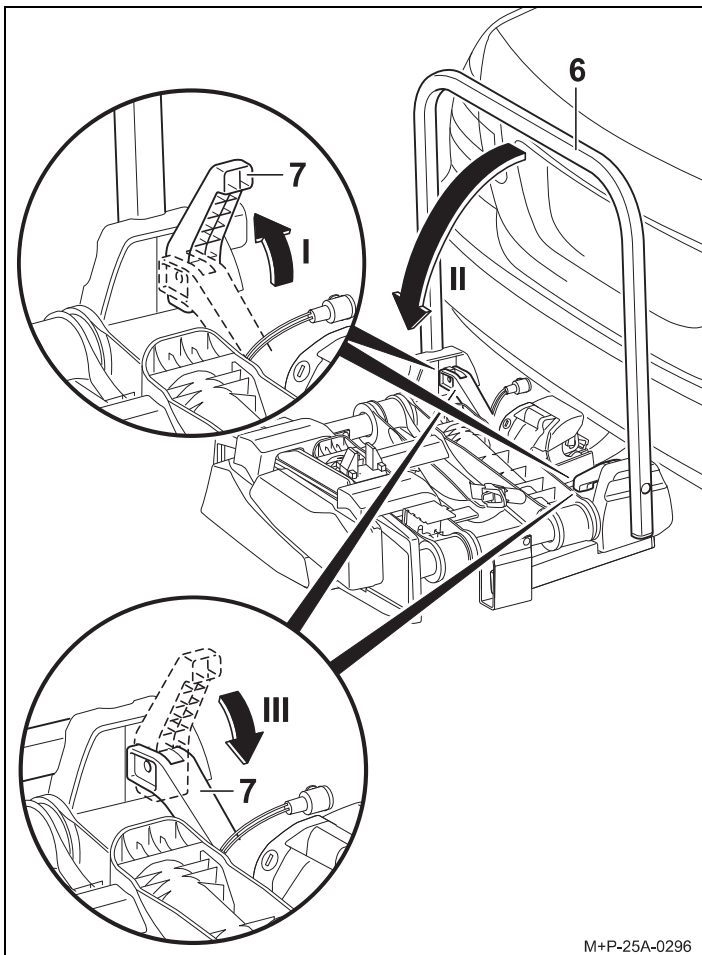

M+P-25A-0296

3. Open the quick-release clamp (7) upwards (arrow I) and fold down the rack frame (6) (arrow II).
4. Close the quick-release clamp (7) again completely (arrow III) to fix the rack frame (6) in place.

Note

Regularly clean the quick-release clamps (7) and rack frame (6) with soapy water, especially if they are dirty or stiff.

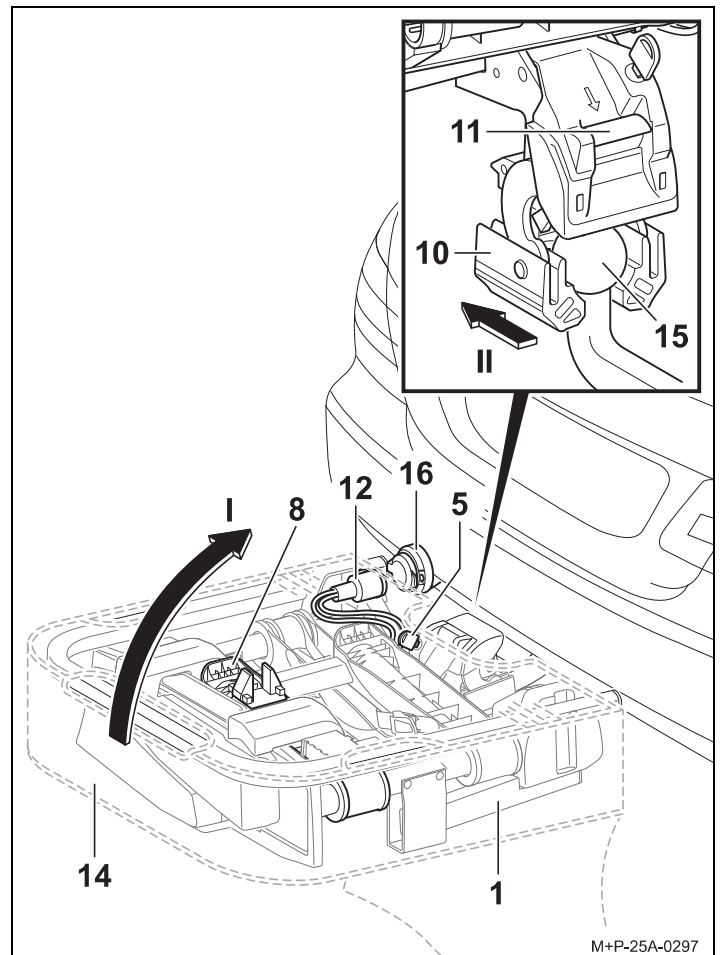

M+P-25A-0297

5. Remove the plug (12) from the socket (16) and push it into the plug holder on the wheel rail (8).
6. Unlock the bicycle rack (1) using the key (5).
7. Push the bag (14) onto the bicycle rack (1).
8. Press the safety lever (11) and push the bicycle rack (1) upright (arrow I).
9. Pull the bicycle rack (1) back off the ball head of the towbar (15) (arrow II).
10. Put the bicycle rack (1) with the attachment (10) on the ground to close the attachment (10).
11. Close the cover of the bag (14).

Attaching and removing bicycles

⚠ Attention

The towbar rack is only intended for transporting bicycles. None of the bicycles carried on the rack may weigh more than 66 lbs (30 kg).

The maximum load capacity of the bicycle rack, the weight on the towbar, the gross vehicle weight rating and the gross axle weight rating (see vehicle owner's manual) may not be exceeded. Otherwise, the rack and the bicycles mounted on it may come loose, injuring other persons or causing an accident.

⚠ Attention

The bicycles must be mounted evenly and with a low centre of gravity on the bicycle rack. Each must be secured against falling off using a bracket on the bicycle frame and lashing straps on front and rear wheels.

Otherwise, the bicycles and/or loose parts could become detached from the vehicle, causing an accident and possible property damage and injury to other road users.

Before mounting, remove child seats and all loose parts such as water bottles, saddlebags and rechargeable E-bike batteries from the bicycles and put them away.

⚠ Attention

There is a risk of injury if bicycles slip off or fall over. Make sure that the bicycles cannot slip off or fall over.

Only put on and take off the bicycles with the help of another person.

⚠ Attention

On some types of vehicle, the rack and the bicycles may be positioned too close to the vehicle's exhaust system. The hot exhaust pipe and fumes can damage the rack and/or the bicycles. In this case, the bicycle rack is not suitable for use.

For bicycles with carbon parts, consult the manufacturer/ dealer to find out whether they are suitable for transport on the bicycle rack.

Arrangement of the bicycles

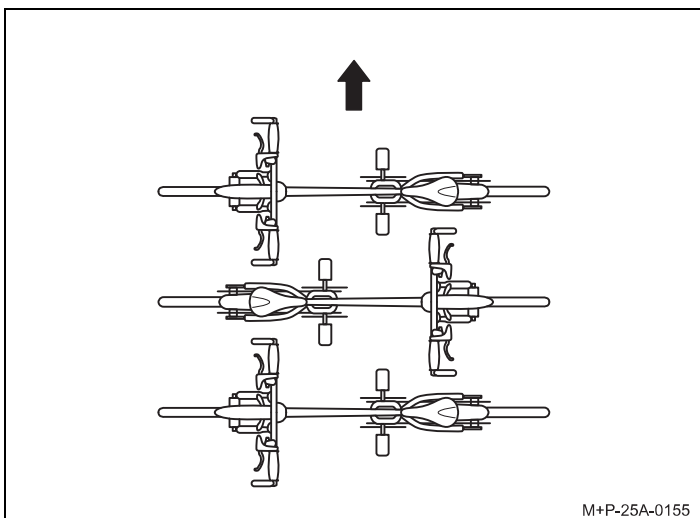

M+P-25A-0155

Note that the bicycles are mounted in opposite directions in the direction of travel (arrow).

Note

Mount heavy bicycles close to the vehicle and light bicycles (e.g. children's bikes) further to the rear on the rack. Mount the first bicycle with its sprocket facing the vehicle.

Mounting the first bicycle

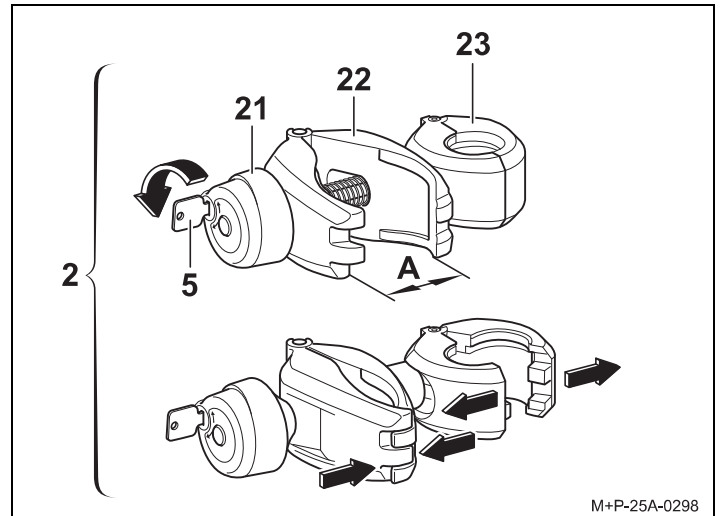

M+P-25A-0298

1. Unlock the twist grip (21) using the key (5).
2. Screw on the twist grip (21) until the clamp (22) opens (A).
3. Press the clamp (22) together and hold. The clamp (23) opens.

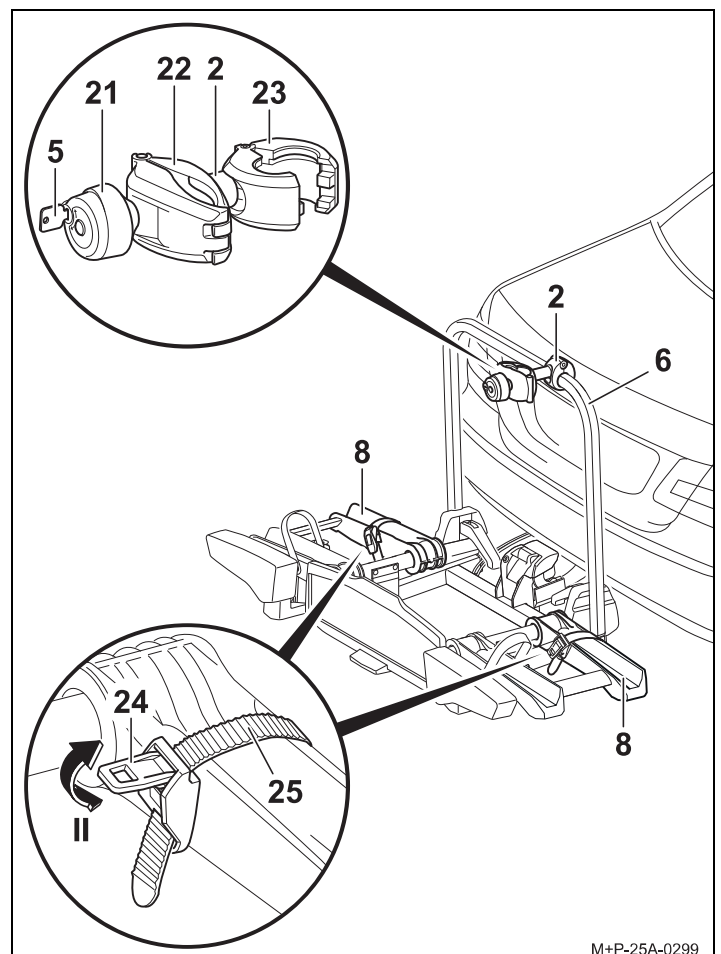

M+P-25A-0299

4. Position the opened clamp (23) around the rack frame (6) and release the pressed-together clamp (22). The clamp (23) closes.
5. Press the tensioner (24) (arrow II) and pull out the lashing strap (25).

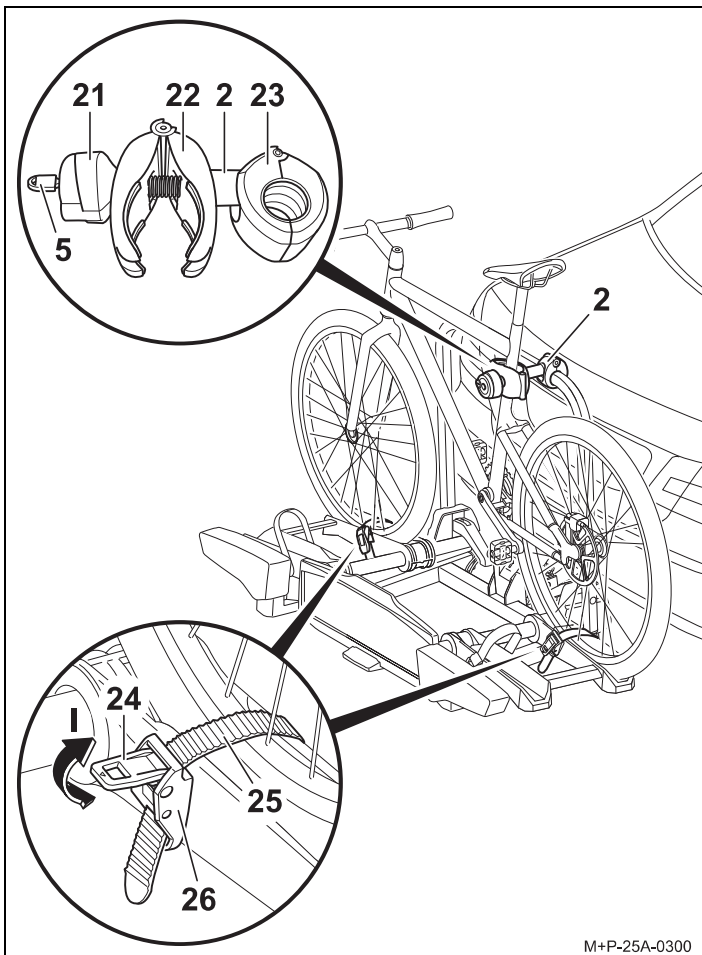

M+P-25A-0300

⚠ Attention

Only attach the holder (2) to the bicycle frame, as other parts of the bicycle could be damaged. Do not pinch components such as gear or brake cables. Defective holders must be replaced immediately.

6. Place the bicycle on the wheel rails and position the holder (2) with the clamp (22) towards the bicycle frame. Secure the bicycle against tipping.
7. Screw the clamp (22) to the bicycle frame with the twist grip (21).
8. Lock the holder (2) using the key (5) and then remove it.
9. Guide the lashing straps (25) between the middle of the wheel spokes.
10. Thread the lashing strap (25) into the buckle (26) and tighten it.

⚠ Attention

Do not tighten the lashing straps (25) too firmly, otherwise the tyres or rims could be damaged.

11. Use the tensioners (24) to tighten the lashing straps (25) (arrow I).

Note

The threaded rods in the holders must be regularly cleaned and greased to prevent the twist grips from seizing up.

Mounting the second bicycle

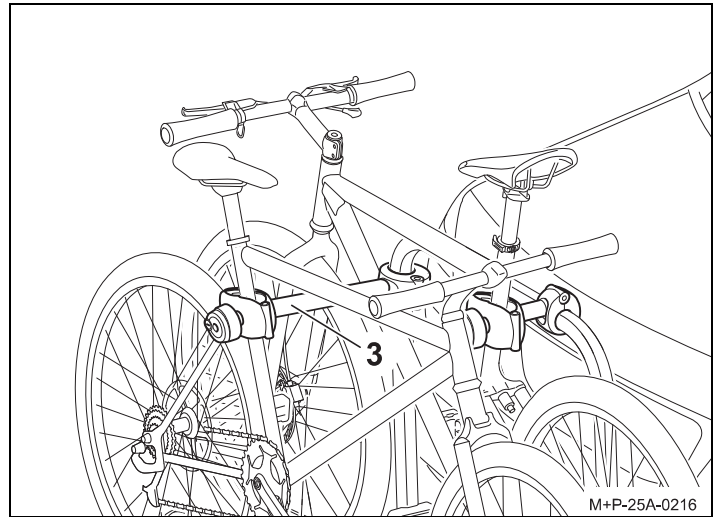

M+P-25A-0216

⚠ Attention

Only attach the holder (3) to the bicycle frame, as other parts of the bicycle could be damaged.

Do not pinch components such as gear or brake cables. Defective holders must be replaced immediately.

The second bicycle is mounted in the same manner as the first. Note that the bicycles are mounted in opposite directions.

Mounting the third² and fourth³ bicycles

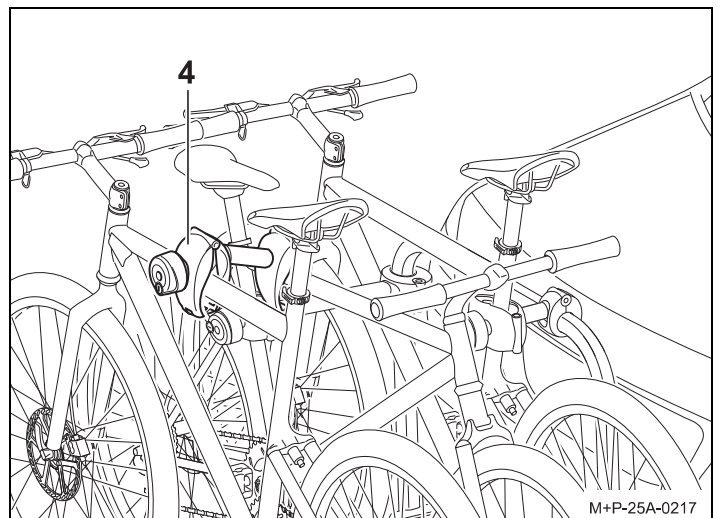

M+P-25A-0217

⚠ Attention

Only attach the holder (4) to the bicycle frame, as other parts of the bicycle could be damaged.

Do not pinch components such as gear or brake cables. Defective holders must be replaced immediately.

The third and the fourth bicycle is mounted in the same manner as the first. Note the opposite arrangement of all bicycles. The third bicycle is attached to the second one with the holder (4). The fourth bicycle is attached to the third bicycle using the second holder (4).

-
- 2 Uebler i31 S rack for 3 bicycles
 - 3 Uebler i41 S rack for 4 bicycles

Removing the bicycles

Release the holders (2), (3) and (4) and remove the bicycles in the reverse order.

Put the holders (2), (3) and (4) in the side pocket of the bag (14).

Folding the bicycle rack down and back up again

⚠ Attention

Slowly fold the bicycle rack down, making sure that no persons or objects are in the way. People may sustain crush injuries and objects may be damaged if they get in the way.

Make sure the bicycle rack engages fully with both hooks and that it locks when folded up, otherwise it could swing down during a journey, injuring you or others and/or causing property damage.

Folding the bicycle rack down

The bicycle rack can be folded down to load and unload the vehicle.

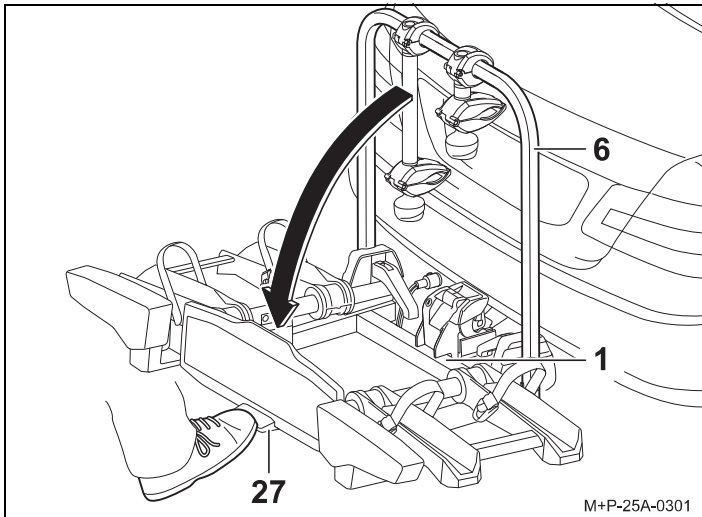

⚠ Attention

When using the Uebler i41 S bike rack (folds 90°), the handlebars of the fourth bicycle may touch the ground due to the larger tilt angle. This may result in damage to the handlebars. Remove the bicycle when folding it down, if necessary.

Press the foot lever (27) and pull the bicycle rack (1) down by pulling on the rack frame (6) or on the frame of a mounted bicycle.

Folding the bicycle rack back up

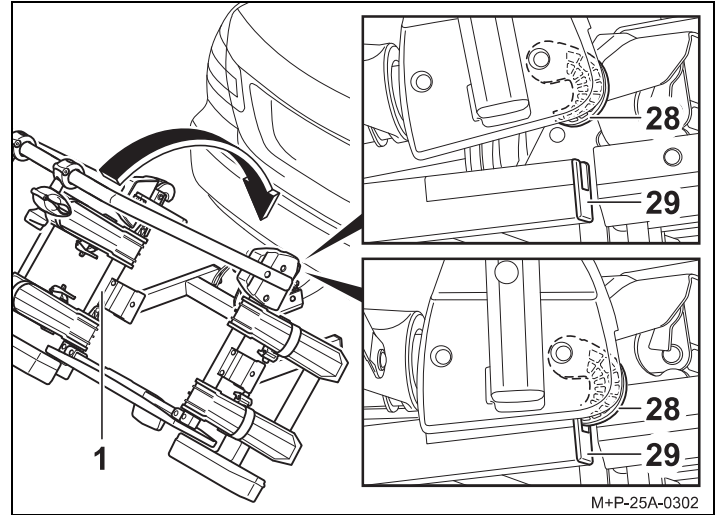

1. Fold the bicycle rack (1) back up so that both hooks (28) are fully engaged and lock into the frame (29).
2. Shake the bicycle rack (1) to ensure that it is seated firmly. If necessary, fold the bicycle rack (1) down and back up again.

Preparation before driving

⚠ Attention

Always check all screw connections and fastenings of the bicycle rack and the bicycles after every assembly, before every trip and at intervals during lengthy trips to make sure they are sitting firmly, and retighten them if necessary. Otherwise, the rack and the bicycles mounted on it may come loose, injuring other persons or causing an accident. Repeat this check at regular intervals depending on road conditions.

⚠ Attention

Check that the lights are in perfect working order before each journey, otherwise accidents may occur.

Note

The number plate and the lights on the bicycle rack must not be obscured.

If the bicycle rack is not fully loaded, make sure that:

- Unused holders were removed from the rack frame and safely stowed in the luggage compartment
- All keys are removed and kept in a safe place
- The lashing straps on all the wheel rails are closed

Changing bulbs

⚠ Attention

When changing bulbs the vehicle ignition must be switched off and the plug for the lights removed from the towbar electrical socket. Failure to do so can result in a short circuit or other damage. If you are not sure, have the bulbs replaced by a specialist workshop.

Note

The lamp change is described and illustrated using the left tail light unit on the bicycle rack. The procedure is the same for the right tail light unit.

Note

When ordering a new bulb, the designation for the bulb concerned must be specified.

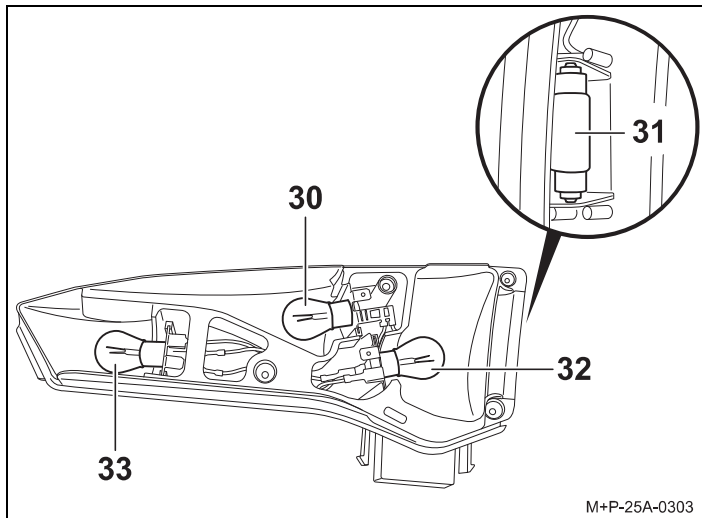

Designation	Spare part no.
30 Indicator ^a BL PY21W 12 V yellow	E1687
31 Number plate lighting ^a BL C5W 12 V (35 mm long) white	E1687
32 Rear fog light ^a for left tail light unit BL PR21W 12 V red Reversing light ^a for right tail light unit BL P21W 12 V white	E1687
33 Brake/tail light ^a BL P21/5W 12 V white	E1687

^a Commercially available bulb.

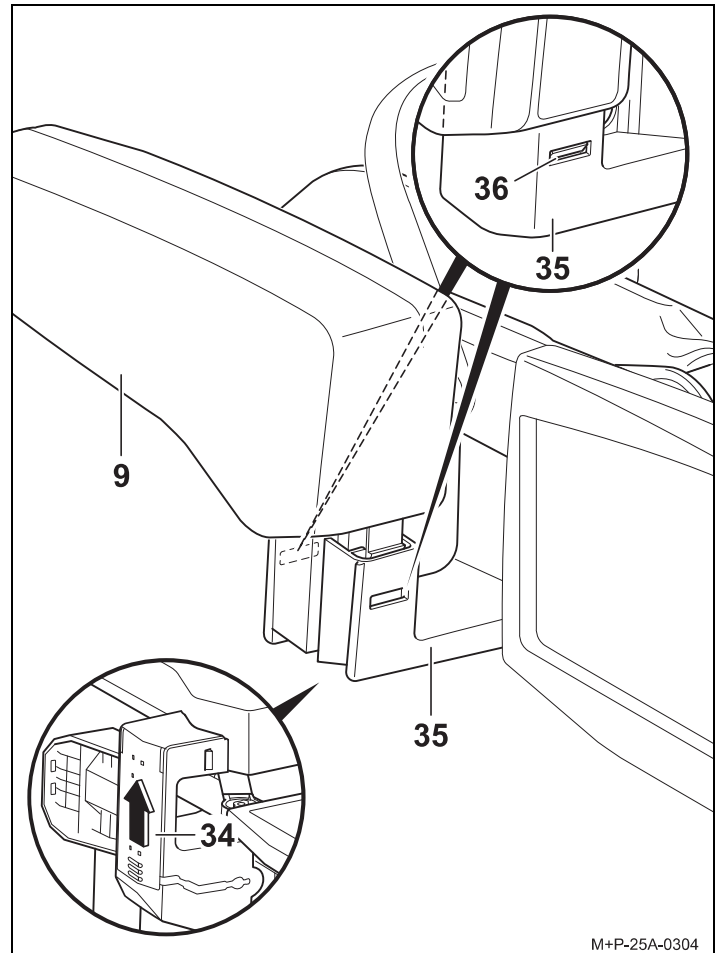

1. Slide the cover (34) on the bottom of the holder (35) in the direction shown by the arrow and remove the cable below it all the way out of the holder (35).
2. Press the catches (36) and carefully pull the tail light (9) out of the holder (35).

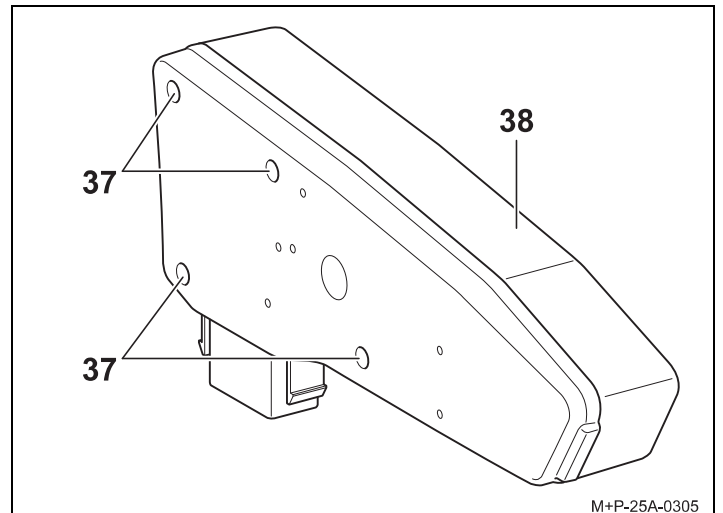

3. Unscrew the screws (37) and take off the lens (38).

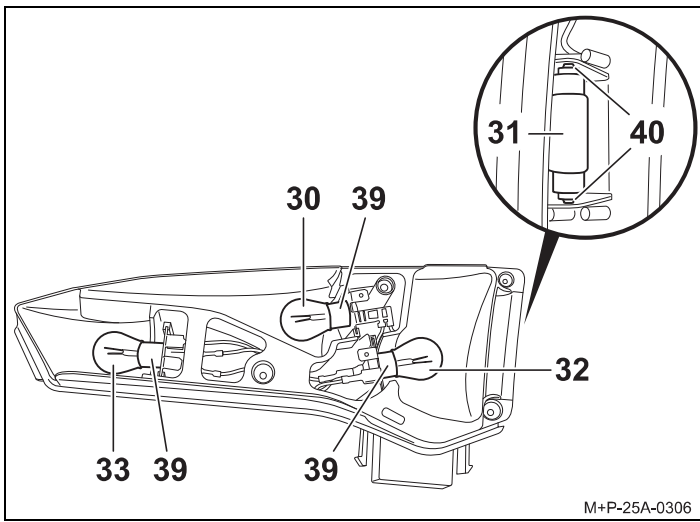

4. Press the defective bulb (30, 32, 33) gently into the socket (39), turn it 90° anticlockwise and pull it out.
5. Pull the bulb (31) out of the socket (40).

Note

Making sure you use a clean cloth, pick up the new bulb and insert it in the socket (39, 40).

6. Gently press the new bulb (30, 32, 33) into the socket (39) and turn it 90° clockwise. Required bulbs, see page 20.
7. Gently press the new bulb (31) into the socket (40). Required bulb, see page 20.
8. Put the lens (38) back in and fasten it hand tight with the screws (37).
9. The rear light (9) is installed in reverse order. The catches (36) and the cover (34) must audibly engage.

General safety instructions

Vehicle owners are responsible for ensuring that their field of view and hearing are not impaired by the bicycle rack, the bicycles or the condition of the vehicle. They must ensure that the vehicle, the bicycle rack and the bicycles are compliant with regulations and that road safety is not impaired. The required lighting systems and equipment must also be present and operational during the day.

These assembly and operating instructions contain the general approval of the bicycle rack for towbars and must always be kept in the vehicle when the rack is mounted.

Observe the legal regulations regarding use of the bicycle rack in the country of use.

Attention

Please observe the work and safety instructions described in these mounting and operating instructions at all times. The bicycle rack for the towbar is intended only for transporting bicycles. The bicycle rack is not suitable for use on rough terrain.

Always check all screw connections and fastenings of the bicycle rack and the bicycles after every assembly, before every trip and at intervals during lengthy trips to make sure they are sitting firmly, and retighten them if necessary. Repeat this check at regular intervals depending on road conditions.

During the trip, the driver should check in the rear view mirror if the bicycle rack and bicycles move or change position.

If changes occur, proceed to the next possible stopping area at reduced speed and retighten the screw connections and attachments of the bicycle rack or bicycles.

Otherwise, the rack and the bicycles mounted on it may come loose, injuring other persons or causing an accident.

Attention

Moving parts such as threaded rods in the holders and quick-release clamps must be regularly cleaned and greased so that the twist grips do not seize up.

Do not use lubricants on any other screw connections. This could cause the screw connections to loosen and the bicycle rack together with the mounted bicycles may free themselves from the vehicle; this may cause injury to you and other persons, or may result in an accident.

Attention

If the mounted bicycles extend more than 16 inch (40 cm) beyond the outer edge of the illuminated surface of the side marker lights or tail lights of the bicycle rack, then they must be marked at no more than 16 inch (40 cm) from the edge and 59 inch (150 cm) above the road with a white light at the front and a red light at the back.

Separately mark the bicycle wheels extending out laterally during transport.

When driving at night, cover the rear lights and reflectors of the bicycles to prevent confusion with the vehicle's tail lights and to avoid impairing or confusing other road users.

Failure to observe this may cause accidents.

Attention

Before starting a trip, check that the lights are functioning correctly. When the rear fog light on the bicycle rack is switched on, the rear fog light of the vehicle must be switched off, i.e. they must not be illuminated at the same time.

In vehicle models whose type approval was initially issued after 1 October 1998, neither the attached rear rack system nor the mounted bicycles may cover the vehicle's third brake light.

The vehicle's third brake light must be visible to the left and right, relative to the vehicle's longitudinal axis, at a horizontal angle of 10° relative to the top edge of the lamp, at a vertical angle of 10°, and, relative to the lower edge of the lamp, at a vertical angle of 5°.

If these values are not met, a "third" replacement brake light must be installed.

Failure to observe this may cause accidents.

⚠ Attention

The mounted bicycle rack and bicycles alter the vehicle's driving and braking characteristics as well as its susceptibility to side winds. Do not exceed a speed of 81 mph (130 km/h).

Do not cover the bicycles with items such as tarpaulins or protective covers as this greatly affects the driving characteristics by increasing the area exposed to the wind.

Slide any heavy cargo in the luggage compartment as far forward as possible to avoid excessively loading down the rear of the vehicle.

Always drive appropriately to the road, traffic and weather conditions and take special care when driving with a loaded bicycle rack.

Otherwise, the rack and the bicycles mounted on it may come loose, injuring other persons or causing an accident.

⚠ Attention

If the vehicle has an electrically operated rear lid, allow for the necessary clearance when mounting the bicycle rack. If possible, deactivate the electric rear lid and operate it manually.

Remove the bicycle rack before using automatic car washes. Otherwise, the bicycle rack, the vehicle and/or the car wash could be damaged.

Note on disposal

Dispose of components, accessories and packaging for environmentally sound recycling. Do not dispose of the lamp unit with household or residual waste.

According to the European Directive 2012/19/EU and national laws, electrical equipment that is no longer usable must be collected separately and recycled in an environmentally friendly manner.

Separate the lamps from the rack and take the components that are no longer usable to a suitable collection point.

Ask your specialist dealer for advice.

